

# VOLspeed Ebike Tuning

Yamaha PW-X / PW-X2 / PW-SE /  
PW-ST / PW-TE / PW-CE  
V3

## Operating instructions

as original operating instructions in English language



1	General information .....	3
1.1	Safety instructions .....	3
2	Requirements for safe use .....	4
2.1	Intended use .....	4
2.2	Restrictions on use.....	4
2.3	Know and comply with installation requirements .....	5
2.4	Obligation of the owner.....	7
2.5	Obligation of each user.....	7
3	Warranty and liability .....	8
3.1	Warranty and liability of the tuning module manufacturer .....	8
3.2	Warranty, guarantee and liability by the manufacturer of the e-bike.....	8
3.3	Property damage and personal injury - Further exclusions of liability to be considered ...	8
4	Functional description .....	10
5	Technical data .....	10
6	Installation .....	11
6.1	Installation example PW-SE on the Haibike SDURO FullSeven 6.0 .....	11
6.2	Installation example PW-X on the Haibike SDURO FullSeven 10.0 .....	14
7	Speed mode .....	17
7.1	Switch on .....	17
7.2	Switch off .....	17
8	Individual activation code.....	18
8.1	Preparation .....	18
8.2	Set code .....	18
8.3	Delete code.....	19
9	Dynamic mode .....	20
10	Change wheel circumference .....	21
11	Range and charge level indicator .....	22
12	Restore factory settings.....	22
13	Status display .....	22
14	FAQ.....	23

## 1 General information

- ▶ Be sure to take the time to read these operating instructions carefully **before** starting to install the tuning module.
- ▶ Keep these operating instructions in a safe place, yet within easy reach, so that you always have access to the important and safety-relevant information for use, even after installation.
- ▶ Make these operating instructions available for reading to any other person who may ride your tuned e-bike.
- ▶ Ensure that every person who is allowed to ride your tuned e-bike has read and understood these operating instructions before any use.
- ▶ Instruct the user in the safe use of the tuned e-bike with the aid of these operating instructions before leaving your tuned e-bike to other persons.
- ▶ Be sure to pass this manual on to the future owner if you ever want to sell the tuning module or your tuned e-bike.

### 1.1 Safety instructions

The warnings used in these instructions draw your attention to possible dangers. You endanger yourself and others if you do not follow these instructions. Serious injuries or considerable damage to property may result.

Warning notices are available in the following categories:

#### **WARNING**

Warns you of hazards that could result in fatal or serious injury to persons if you do not follow these instructions.

#### **CAUTION**

Warns you of hazards that may result in minor, usually reversible injury to persons if you do not follow these instructions.

#### **ATTENTION**

Warns you of situations that can lead to property damage and malfunctions during use if you do not follow these instructions.

#### **IMPORTANT**

Identifies safety-relevant descriptions and instruction parts.

## 2 Requirements for safe use

### 2.1 Intended use

The tuning module shifts the cut-off threshold of the motor support of your e-bike. Thus, with the installation of the tuning module, speeds of up to 45km/h (28mph) can be achieved with electric motor support.

Intended use also includes compliance with all of the following without exception

- Restrictions on use and
- Installation requirements and the
- Obligations of the owner and the user.

### 2.2 Restrictions on use

The following restrictions of use are associated with the installation of the tuning module in your e-bike.

#### 2.2.1 Do not use in public areas

E-bikes for use on public roads or public ways with a permitted speed of > 25 km/h are subject in the EU to Regulation 168/2013/EU, the Vehicle Regulation. Further approval requirements in non-European countries may apply. The purchase of the Tuning Module does not entail any approval for operation in public areas. Therefore, participation in public road traffic and driving on public roads is prohibited after installation of the tuning module.

#### **IMPORTANT** Prevent misuse and abuse

- ▶ Only use your tuned e-bike on private, secured property or race tracks.
- ▶ Never ride on public paths or areas that you have not previously been able to securely block off against entry by other persons.
- ▶ Also prevent another person from using your tuned e-bike in public traffic or on public roads.
- ▶ Always lock your tuned e-bike when you park it. This will prevent misuse and abuse, even by other people.

#### 2.2.2 Restricting the circle of users

Reaching higher speeds can lead to the permissible group of users determined by the e-bike manufacturer having to be further restricted.

Such a restriction must be determined by the owner of the tuned e-bike on his own responsibility, taking into account the physical and mental fitness of the persons to whom the tuned e-bike is made available for use.

#### **IMPORTANT** Prevent misuse and abuse

- ▶ Clearly define the permission for use before each transfer to other persons.
- ▶ Also clearly define the terrain to be covered.
- ▶ Always lock your tuned e-bike when you park it. This will prevent misuse and abuse by other people.

### 2.2.3 Observe shortened maintenance and inspection intervals

Due to the higher speeds with electric motor assistance, higher loads and forces will act on all vehicle parts.

Reaching higher speeds increases wear on all vehicle parts, especially the brake system and all parts of the drive system, even with suitable strength and design of the vehicle.

#### **IMPORTANT** Define shortened maintenance and inspection intervals

Shortened inspection and maintenance cycles must be determined by the owner of the tuned e-bike on his own responsibility, taking into account the conditions of use.

- ▶ Before each use of your tuned e-bike, perform a comprehensive inspection of the vehicle.
- ▶ It is imperative that you check the condition and function of the
  - brakes and their functional components,
  - vehicle frame,
  - steering system and its functional components,
  - drive system and its functional components as well as
  - saddle and its functional components.
- ▶ In addition, observe all inspections not mentioned here that are prescribed by the manufacturer of your e-bike before each use. This list does not replace the original operating instructions of the e-bike manufacturer.
- ▶ Establish further inspection and maintenance cycles according to the manufacturer's instructions for your e-bike.
- ▶ Shorten them according to your operating conditions.
- ▶ If necessary, coordinate this with your specialist company, which will carry out the inspection and maintenance work.

This ensures that the shortened inspection and maintenance intervals are adhered to.

## 2.3 Know and comply with installation requirements

For safe use of the tuning module in your e-bike, your bike must also meet some requirements.

### 2.3.1 Requirements for the strength and construction of the bike

Strength and construction requirements are regulated by EN 15194 and EN ISO 4210-2 and must be confirmed as applied by the manufacturer of your e-bike.

#### **WARNING** Prevent increased accident risks due to insufficient strength

Due to the higher speeds with electric motor assistance, higher loads and forces will act on all vehicle parts. Increased accident risks due to part breakage and part failure can only be largely ruled out with e-bikes that are demonstrably designed and built in accordance with both product standards.

- ▶ Check the EC declaration of conformity of the manufacturer of your e-bike.

- ▶ Only install the tuning module in your e-bike if the manufacturer of your e-bike states the two product standards EN 15194 and EN ISO 4210-2 as applied in its EC declaration of conformity.
- ▶ Only if both standards are mentioned as applied, it can be assumed that the requirements for strength and design are fulfilled.
- ▶ Never use the tuning module in vehicles for which you cannot clearly establish these requirements and prove them by means of the EC declaration of conformity from the e-bike manufacturer.

### **IMPORTANT** Racing bikes, city bikes or trekking bikes are usually not equipable

Racing bikes, city bikes or trekking bikes often do not meet the requirements for strength and construction, as lower requirements apply to these types of bikes. Furthermore, it cannot be assumed that these bikes are actually only used on private, secured properties or race tracks.

### 2.3.2 Check and confirm drive system and display requirements

The tuning module is adapted to specific drive systems and display types.

- ▶ Check the equipment of your e-bike.
- ▶ The tuning module only works with e-bikes that have an electric motor support of up to 25km/h ex works. Children's e-bikes with a support up to 20km/h and Speed-e-bikes with a support up to 45km/h are not supported.
- ▶ Only install the tuning module into your e-bike if you can determine that your e-bike equipment matches the drive systems and display types listed below.

Drive system:	Display type:
Yamaha - PW-X	Display X, Display A, Display C
Yamaha - PW-X2	Display X, Display A, Display C
Yamaha - PW-SE	Display X, Display A, Display C
Yamaha - PW-ST	Display X, Display A, Display C
Yamaha - PW-TE	Display X, Display A, Display C
Yamaha - PW-CE	Display X, Display A, Display C

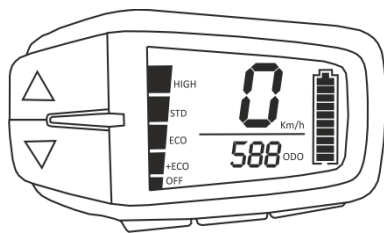

Display A (Sideswitch)

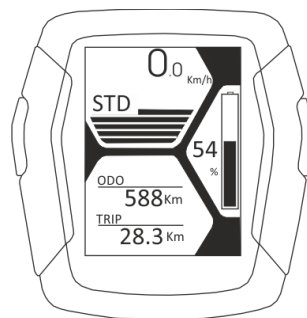

Display C (Multiswitch)

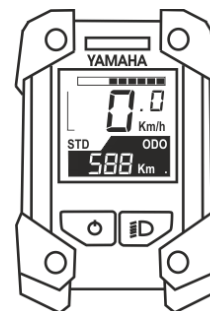

Display X



### Compatibility

The tuning is NOT compatible with the following motors:

- Yamaha PW, PW-X3
- all Giant Syncdrive motors

### **IMPORTANT** Prevent damage and malfunctions

Use in vehicles with unsuitable drive systems and/or display types will lead to malfunctions or damage to the e-bike or the tuning module.

#### 2.4 Obligation of the owner

Any user of the tuned e-bike must be instructed accordingly by the owner of the tuned e-bike on the basis of these operating instructions, as well as being informed about the special restrictions on use and increased risks due to the increased speed.

The owner of the tuned e-bike ensures that

- ▶ all requirements for safe use
- ▶ and for the intended use are complied with, and
- ▶ these operating instructions are always available to every user.

The owner of the tuned e-bike undertakes to only make the tuned e-bike available to persons who

- ▶ have read and understood these operating instructions and
- ▶ have been instructed in the safe and proper use of the tuned e-bike.

#### 2.5 Obligation of each user

Every user is obliged,

- ▶ to read and observe these operating instructions in full, and
- ▶ to follow all safety and warning instructions without exception,
- ▶ to use the tuned E-bike only in technically perfect condition and in accordance with its intended purpose, in a safety-conscious and hazard-conscious manner and in compliance with these operating instructions and
- ▶ to remedy immediately any damage or malfunctions detected which could impair safety, or, if necessary, to have them remedied.

### 3 Warranty and liability

#### 3.1 Warranty and liability of the tuning module manufacturer

Warranty and liability claims are excluded by the manufacturer of the tuning module in the event of direct or indirect personal injury or damage to property if they are attributable to one or more of the following causes:

- ▶ Increased wear or breakage of components of the E-bike, especially parts of the brake system and/or the ride,
- ▶ non-observance of these operating instructions or
- ▶ improper use of the tuning module or the e-bike with integrated tuning module, or
- ▶ non-observance of the operating restrictions of these operating instructions or
- ▶ use or operation with operating conditions that do not comply with these operating instructions, or
- ▶ improper installation, commissioning, maintenance or repair not specified in these operating instructions, or
- ▶ after unauthorised structural, hardware or software modifications to the tuning module itself or to the e-bike approved for the tuning module or its equipment.

**IMPORTANT** The installation and operation of the tuning module is at your own risk.

- ▶ The manufacturer of the tuning module does not accept any liability for damage related to the operation or installation of the tuning module.
- ▶ The technical and legal consequences mentioned may be incomplete.
- ▶ In addition to the technical and legal consequences mentioned in these operating instructions, further requirements may apply depending on the place of operation.
- ▶ Before installing the device, inform yourself about possible further technical and legal consequences and requirements that you must comply with in order to operate the tuned e-bike.

#### 3.2 Warranty, guarantee and liability by the manufacturer of the e-bike

Due to the higher speeds with electric motor assistance, higher loads and forces will act on all bicycle parts.

Reaching higher speeds increases wear on all bicycle parts, especially the braking system and all parts of the drive system, even if the vehicle is of suitable strength and design.

For this reason, liability, warranty and guarantee claims against the dealer or manufacturer of the e-bike will expire or be severely limited with the use of the tuning module.

#### 3.3 Property damage and personal injury - Further exclusions of liability to be considered

An e-bike can reach electric motor-assisted speeds of up to 45 km/h after the tuning module has been installed. Reaching such speeds increases the risk of a fall and resulting injury, even with



suitable strength and design of the vehicle. It also increases the risk of damaging other people or property.

**ATTENTION** Reduce increased liability risks

- Precisely define your operating conditions and user groups to be insured.
- Take out liability insurance appropriate to the conditions of use and the user group for the use of your tuned e-bike.

 **WARNING** Reduce increased risk of hazards

- Always wear suitable protective clothing and a crash helmet while using your tuned e-bike to protect yourself from increased risk of accidents.
- Insist that every user of your tuned e-bike wears appropriate protective clothing and a crash helmet at all times during use.

**ATTENTION** Reduce the risk of accidents monetarily

- Precisely define your operating conditions and user groups to be insured.
- Take out an insurance policy for the use of your tuned e-bike that is appropriate to the conditions of use and the user group.

## 4 Functional description

The Tuning Module offers the following functions after installation in a PW-X, PW-X2, PW-SE, PW-ST, PW-CE or PW-TE drive system 25km/h (15.5mph):

- ▶ Adjustable speed limit up to 45km/h (28mph) via the control unit on the e-bike
- ▶ Personal activation code adjustable
- ▶ Adjustable dynamic mode, reduced "wall effect"
- ▶ Correct display of speed and distance travelled
- ▶ Correct total odometer reading after re-removal of the tuning module
- ▶ Optimised range calculation with active tuning
- ▶ Wheel circumference adjustable



### Setting options

All settings are made via the display on the e-bike.  
No smartphone or notebook is required.

### Protected electronics

The electronics are cast into the housing and thus safely protected from moisture.

### Safety and protective devices

Safety and protective devices of the E-bike remain unaffected by the installation of the tuning module.

## 5 Technical data

Housing dimensions:	37mm x 19mm x 9mm (1.46" x 0.75" x 0.36")
Cable length:	Approx. 140mm (5.5")
Weight:	0.025kg (0.9oz)
Power consumption:	0.1W
Supply voltage:	5VDC

## 6 Installation

### **IMPORTANT** Before you start the installation

Confirm that you have carefully and completely read and understood all previous chapters of these operating instructions before you begin with the installation. This is the only way to ensure that you use the Tuning Module exclusively for the purpose described in these instructions and as intended.

### 6.1 Installation example PW-SE on the Haibike SDURO FullSeven 6.0

The installation described below and all associated instructions refer to the installation example: Haibike SDURO FullSeven 6.0 with PW-SE motor. The installation of the PW-ST, PW-TE or PW-CE is almost identical due to the identical mechanical motor design.



#### **PW-X / PW-X2**

In chapter 6.2 you will find an installation example for the PW-X.

#### 6.1.1 Required tools

- Allen key 3mm
- Allen key 6mm
- Torque Ratchet with Allen 6mm



#### **Further tools may be necessary**

The engine cover may also be fastened with Torx or Phillips screws, depending on the vehicle model.

#### 6.1.2 Note the part number and serial number



#### **Note for support requests**

- ▶ Make a note of the
  - Part number (P/N) and
  - Serial number (S/N) of the tuning module on the back of these operating instructions.

**This way, you always have the data at hand for any support requests.**

#### 6.1.3 Dismount motor

### **⚠ WARNING** Preventing an unexpected start-up

If the drive starts unexpectedly, hands and fingers can be sheared, crushed or pulled in. Switch off the e-bike and remove the battery. This will prevent any movement supported by the electric motor.

- ▶ Ensure that your e-bike stands firmly and securely.
- ▶ Remove the screws (1) and (2) on the motor protection cover. The screws behind the chainring, not shown here, do not need to be removed.

- ▶ Loosen the fastening screws (3), (4) and (5) of the motor.
- ▶ Remove the screws (3) and (4) completely. Hold the motor firmly and then fold it down.
- ▶ Above the motor, the view of the wiring becomes free.

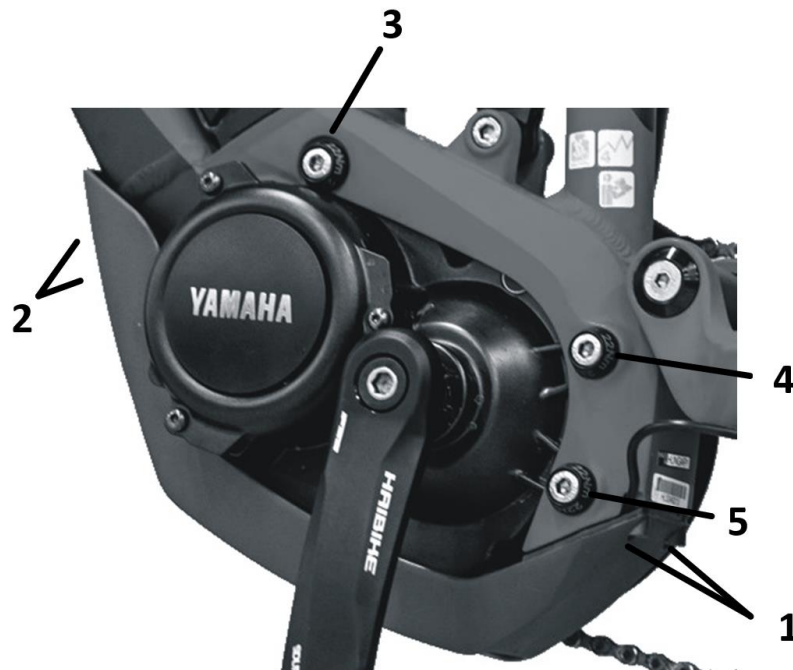

#### 6.1.4 Plug in cable

- ▶ Trace the cables coming from the motor and disconnect the 3-pin and 5-pin connector.

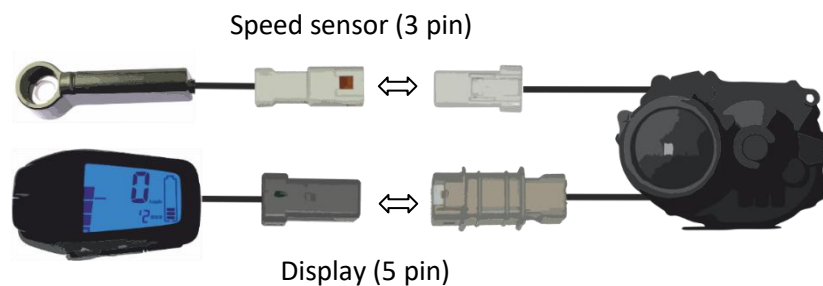

- ▶ Plug the tuning module into the 4 connectors that have become free.

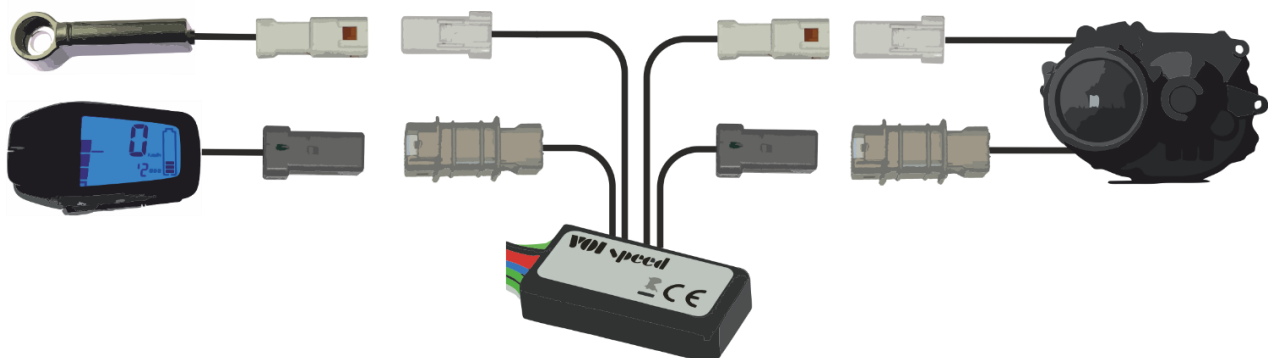

### 6.1.5 Check function

- ▶ Insert the battery into the e-bike.
- ▶ Switch on the bike. When the bike is switched on for the first time, an automatic initialisation is carried out. The display shows 11km/h (11mph) for 10 seconds. Then the display shows 0km/h again.



#### **Wiring faulty**

If the display shows 12km/h (12mph) after about 10 seconds, the speed sensor signal wiring is faulty. Check the connections again according to the illustration in chapter 6.1.4

- ▶ Then check whether you can switch on the speed mode as described in the chapter 7. If this is not possible, check the wiring again carefully.



#### **Set activation code**

If an individual activation code is to be set to protect the Tuning from unauthorised use:

- ▶ Set the activation code according to the instructions in chapter 8 Activation code now.
- ▶ Then check whether you can activate the tuning using the set code.

- ▶ Switch the e-bike off again and remove the battery.

### 6.1.6 Finalize installation

- ▶ Place the tuning module and the connectors in a suitable location.
- ▶ Lay the cables so that they are not crushed when the motor is folded up.



#### **No uniform installation location can be defined**

Due to the different frame geometries, it is not possible to define a uniform installation location. It is often possible to place the module in the down tube, in the seat tube or directly in the connection area of the motor.



#### **Speed sensor cable**

On full suspension bikes make sure that the cable for the speed sensor is long enough at the transition to the chain stay so that it is not stretched when the suspension is compressed.

- ▶ Fold the motor back up and refit the screws (3) and (4).
- ▶ Tighten the screws (3), (4) and (5) to 22Nm.
- ▶ Refit the screws (1) and (2) of the motor protection cover.

## 6.2 Installation example PW-X on the Haibike SDURO FullSeven 10.0

The installation described below and all associated instructions refer to the installation example: Haibike SDURO FullSeven 10.0 with PW-X motor. The installation of the PW-X2 is almost identical due to the identical motor design.

### 6.2.1 Required tools

- Allen key 3, 5 and 6mm
- Torque ratchet with Allen key 4 and 6mm
- Screw locking varnish medium strength or high strength



#### Further tools may be necessary

The motor cover may also be fastened with Torx or Phillips screws, depending on the bike model.

### 6.2.2 Note the part number and serial number



#### Note for support requests

- ▶ Make a note of the
  - Part number (P/N) and
  - Serial number (S/N) of the tuning module on the back of these operating instructions.

**This way, you always have the data at hand for any support requests.**

### 6.2.3 Dismount motor

#### **WARNING** Preventing an unexpected start-up

If the drive starts unexpectedly, hands and fingers can be sheared, crushed or pulled in. Switch off the e-bike and remove the battery. This will prevent any movement supported by the electric motor.

- ▶ Ensure that your e-bike stands firmly and securely.
- ▶ Remove the screws (1) and (2) on the motor protection cover. The screws behind the chainring, not shown here, do not need to be removed.
- ▶ Remove the chain from the sprocket.
- ▶ Loosen the fixing screws (4) of the chainring and remove it.



#### Alternatives

It is also possible to remove the chainring including the spider. However, this requires a tool to loosen the locking ring and a crank puller to remove the pedal crank.

It is also possible to dispense with removing the chainring if the motor mounting bolt (6) can be removed using a modified Allen key or an Allen key with a ball head.

- ▶ Place a box or similar under the motor to rest it on after dismounting. The storage area should be about 20 cm below the motor.

- ▶ Remove the fastening screws of the motor (5), (6) and then (3). Hold the motor with one hand while removing the screws.
- ▶ Place the motor on the storage surface.
- ▶ Connect the tuning module as described in chapter 6.1.4 and then check its function as described in section 6.1.5 described.

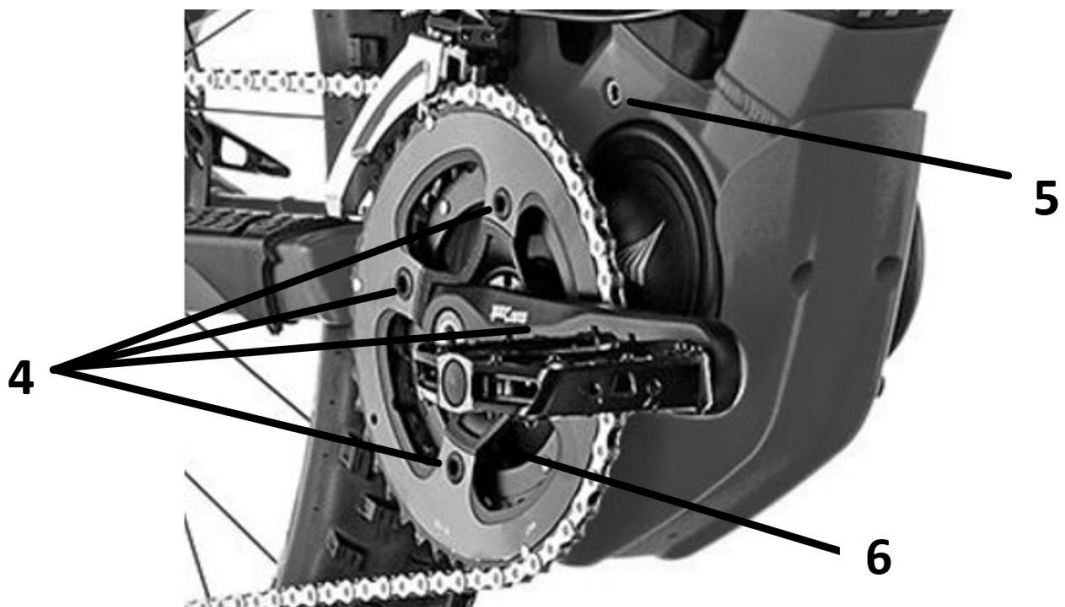

#### 6.2.4 Finalize installation

- ▶ Place the tuning module and the connectors in a suitable location.
- ▶ Lay the cables so that they are not crushed when the motor is reassembled.



##### **No uniform installation location can be defined**

Due to the different frame geometries, it is not possible to define a uniform installation location. It is often possible to place the module in the down tube, in the seat tube or directly in the connection area of the motor.



##### **Speed sensor cable**

On full suspension bikes make sure that the cable for the speed sensor is long enough at the transition to the chain stay so that it is not stretched when the suspension is compressed.

- ▶ Put the motor back in the frame and refit the screws (3), (5) and (6) and tighten them hand-tight.
- ▶ Tighten the screws (3) to 22Nm and then (5) and (6) to 11Nm.
- ▶ Refit the screws (1) and (2) of the motor protection cover.
- ▶ Mount the chainrings again. When doing so, insert the screws (4) with locking varnish. Then tighten with 11Nm.



## 7 Speed mode

When Speed mode is activated, the speed limit for motor assistance is raised. The limit can be freely set in the range 25 to 45km/h (15.5 to 28mph). When the e-bike is switched off, the speed mode is automatically switched off and must therefore be reactivated when the bike is switched on again.



### Note displays

The following illustrations show an example of display A. For display X and C, the corresponding buttons on the control unit must be pressed.

### 7.1 Switch on

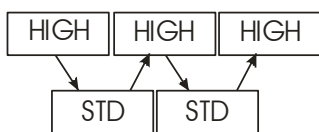

Use the arrow keys to change the support levels as shown.



### Individual activation code

If you have set an individual activation code in accordance with the instructions in chapter 8 enter this instead.

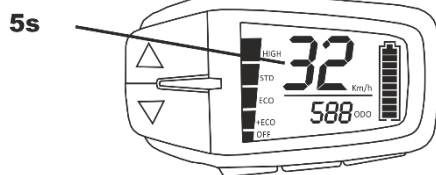

Speed limit is displayed for 5 seconds. Default value 32km/h (20mph). Possible values: 25..45km/h (15.5..28.0mph).

The speed mode is now switched on.

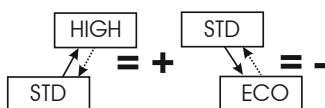

The limit can be changed by switching back and forth between the levels shown. The set value is saved as soon as you do not press any button for 5 seconds.

### 7.2 Switch off

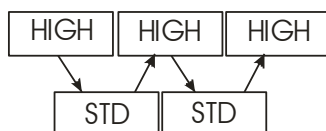

Use "arrow up" and "arrow down" to change the support levels as shown.

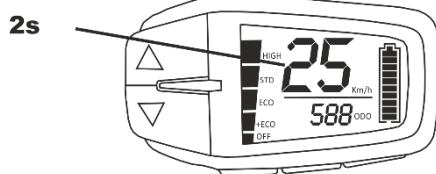

The display shows 25km/h (15.5mph) for 2 seconds. The speed mode is off.

## 8 Individual activation code

With an individual activation code, the speed mode can only be activated by entering this code. This prevents unauthorised activation of the tuning. The code always consists of a self-definable sequence of 5 different support levels that must be selected in the set sequence.

### 8.1 Preparation

- ▶ Switch on the bike and set the display to show the total kilometre reading (ODO) and then switch it off again.
- ▶ Disconnect the two smaller, three-pin connectors of the tuning module from the motor and the speed sensor and plug them together as shown in the following illustration.

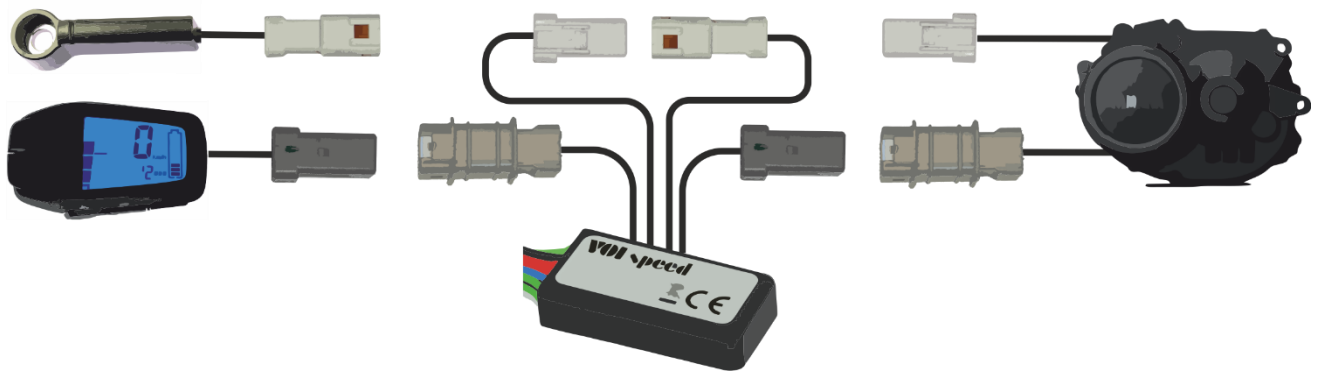

### 8.2 Set code

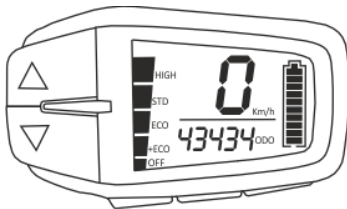

Switch on the bike. "43434" is displayed as the total kilometre reading. This is the default code. Each digit represents a support level according to the following table.

"43434" corresponds to the code: HIGH | STD | HIGH | STD | HIGH

Digit	Level
0	Off
1	+ECO
2	ECO
3	STD
4	HIGH
5	EXPW (PW-X / PW-X2 only)



### Old code invisible

If a code was already set beforehand, it will be deleted. Unauthorised reading of the code is therefore not possible.

- ▶ Now set your own code by changing the support levels.
- ▶ After pressing an arrow key for the first time, the standard code is deleted and the currently set level is displayed instead, see entry example step 2.
- ▶ With each change of support level, the current support level is now appended to the right, see input example step 3 -7
- ▶ Once 5 digits have been entered, the code is complete and can be saved.
- ▶ If more digits are entered, the first digit is deleted with each new entry, see step 7.

Entry example:

Step	Key	ODO	Level	Note
1	-	43434	STD	Code: HIGH   STD   HIGH   STD   HIGH
2	Arrow down	<b>2</b>	ECO	Code not complete
3	Arrow down	<b>21</b>	+ECO	Code not complete
4	Arrow up	<b>212</b>	ECO	Code not complete
5	Arrow up	<b>2123</b>	STD	Code not complete
6	Arrow down	<b>21232</b>	ECO	Code: ECO   +ECO   ECO   STD   ECO
7	Arrow up	<b>12323</b>	STD	Code: +ECO   ECO   STD   ECO   STD

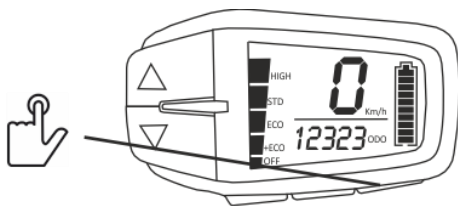

Note down the set code and switch off the bike. This saves the code. If you want to change the code again, simply switch the bike on again and enter it again.

- ▶ Finally, restore the wiring to its original condition.



### Check code entry

Before re-assembling your bike, be sure to check whether you can activate the speed mode with the set code.

## 8.3 Delete code

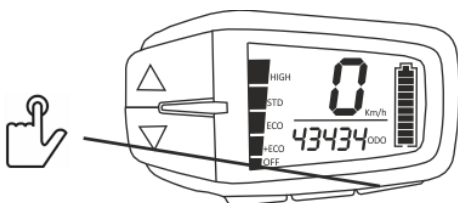

Switch on the bike. The total kilometre reading is displayed as "43434". Switch the bike off again. This deletes the code. Then restore the wiring to its original condition.

## 9 Dynamic mode

If the speed limit is exceeded, the motor power is reduced very strongly by default. A higher pedal force then initially no longer results in a higher speed, but in a lower motor support. For a more natural riding experience, the dynamic mode spreads the downshift over a wider speed range, the so-called "wall effect" is significantly reduced and it is possible to ride with much more constant pedal force.

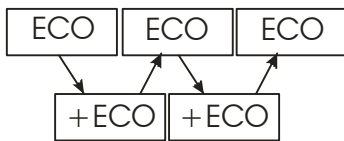
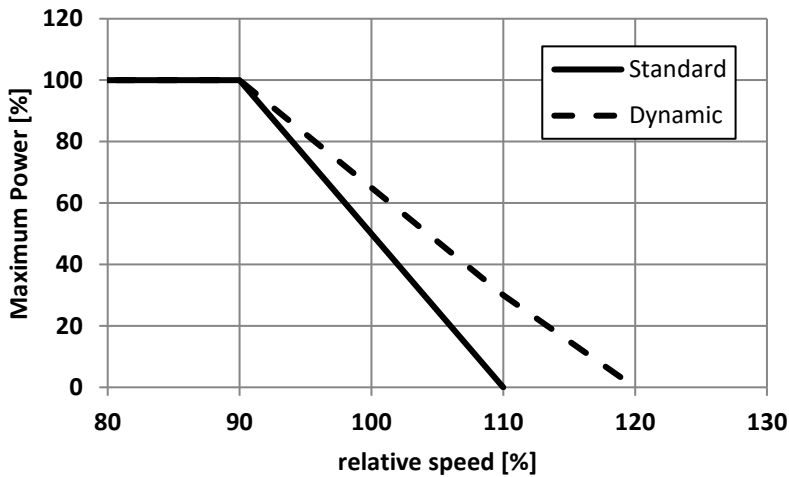

When speed mode is activated, use the arrow keys to change the support levels as shown.

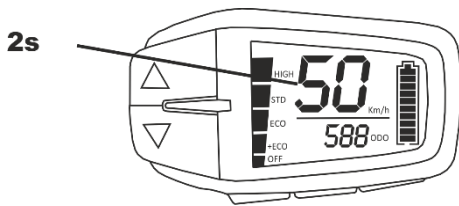

Dynamic mode off: 50 km/h (50mph) is displayed for 2 seconds. The set value is saved.

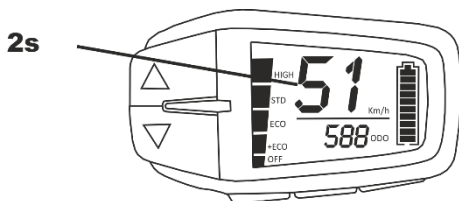

Dynamic mode on: 51 km/h (51mph) is displayed for 2 seconds. The set value is saved.

## 10 Change wheel circumference

The tuning module uses the wheel circumference stored in the motor as standard. Therefore, an adjustment is normally not necessary. However, if the speed display or distance measurement is inaccurate, the value can be adjusted manually by +/- 10%.

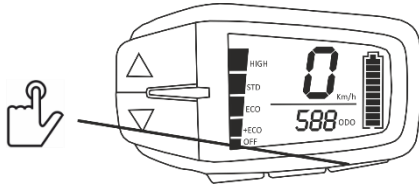

Switch on the e-bike and set the trip or ODO display and activate the speed mode as described in chapter 7.

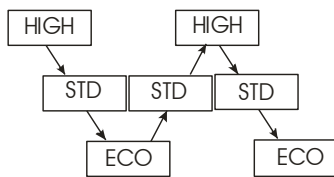

Use "arrow up" and "arrow down" to change the support levels quickly as shown.

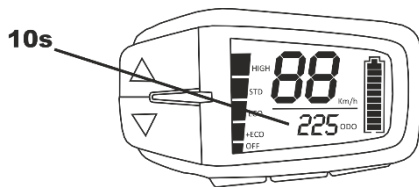

The set wheel circumference is displayed in centimetres as the total and daily kilometre reading (1 centimetre = 1 kilometre). Meanwhile, the speed display shows 88km/h (88mph).

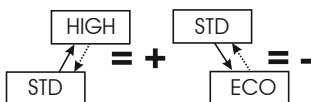

The value can be changed by switching back and forth between the levels shown. The set value is saved.



### Wheel circumference

Do not confuse the value with the tyre diameter, which is often 27.5", 28" or 29". The wheel circumference, on the other hand, is the distance the bike travels in one wheel revolution. You can either measure the value yourself or use the tyre manufacturer's specifications.

Please also note that the value must be set in centimeters. One inch corresponds to 2.54 centimeters.

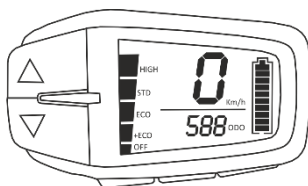

If no button is pressed for 10 seconds, the odometer reading is displayed again and the set wheel circumference is saved.

## 11 Range and charge level indicator

When the speed mode is activated, a range calculated by the tuning module is displayed instead of the value from the motor control unit after 5% battery discharge. The reason for this is that the motor control unit can no longer calculate the range correctly due to the tuning. The tuning module uses the charge level of the battery and the kilometres driven.

## 12 Restore factory settings

The tuning module sets itself up automatically. A conversion to another bike or another display is also recognised automatically. Nevertheless, it is possible to reset the tuning module to the factory settings. The following values are reset:

- ▶ The limit is set at 32km/h.
- ▶ Any existing individual activation code will be deleted.
- ▶ The mileage and wheel circumference is taken from the motor.

To restore the factory settings, first activate the speed mode and then enter the following sequence quickly using the arrow keys:

STD	HIGH	STD	ECO	+ECO	ECO	+ECO
-----	------	-----	-----	------	-----	------

## 13 Status display

Certain operating conditions are displayed by the tuning module as speed to inform the user.

Speed	Meaning
11 km/h (11mph)	Initialisation in progress. The value is displayed for 10 seconds after switching on for the first time or after resetting to factory settings.
12 km/h (11mph)	Speed sensor signal faulty. Check wiring.

## 14 FAQ

### **Speed mode cannot be activated.**

An individual activation code has probably been set. If this is known, you must first enter the activation code. If you have forgotten it, delete the code as described in chapter 8.3 chapter.

### **Why is it not possible to adjust the limit when activating the speed mode?**

To adjust the limit, it is not sufficient to press the up or down arrow key. To increase the limit, you must switch back and forth between the STD and HIGH levels. Each time you switch from STD to HIGH, the limit is increased by one km/h. Similarly, to reduce the limit, you must switch back and forth between the STD and ECO levels. With each switch from STD to ECO, the limit is reduced by one km/h accordingly.

### **Is the total mileage correct even after removing the module?**

Yes, the total kilometres measured by the motor control unit are not changed by the tuning. This is ensured by a compensation function in the tuning module that works continuously in the background. However, before removing the module, the bike should be left at a standstill with the speed mode switched on until it switches off by itself. This ensures that the compensation function has correctly adjusted the kilometre reading.

## Technical support

If you have any questions or problems, please contact us by e-mail or telephone at:

TLI Elektronik GmbH

St.-Martin-Str. 11

D-86676 Ehekirchen

[info@volspeed.de](mailto:info@volspeed.de)

Tel.: +49 (0) 8253 / 9279902

In addition to your request, please provide the following information:

- Article number and serial number of the unit (S/N, P/N)
- Bicycle manufacturer, type and year of construction
- Display type (e.g. Display A)
- Motor type (e.g. PW-X)

To ensure that you always have the unit data at hand, you can enter it here before installing the unit:

Part number (P/N): \_\_\_\_\_

Serial number (S/N): \_\_\_\_\_

## Disposal



Electronic devices are recyclable materials and do not belong in household waste.

At the end of its service life, dispose of the product in accordance with the applicable legal requirements.

